





# GR140C



**Design C**

|                  |               |
|------------------|---------------|
| <b>Fuel Type</b> | <b>Gas</b>    |
| <b>Oven Type</b> | <b>Rotary</b> |

Gas ovens with Design C and rotating base are basic one with metal cover and a brick facade finish – simple, elegant very durable where quality is viable. Those ovens are suitable both for inside kitchen use and building in option where only the oven face will be visible for customers. The rotation of the base provides the flexibility for easier operation, equal baking inside the chamber and higher efficiency.

|   |  |            |  |               |            |
|---|--|------------|--|---------------|------------|
| <b>Capacity</b>   | 13  30 cm     |            | <b>Thermal Power</b>   | 30 kW         |            |
| <b>Productivity</b>   | 195  per hour |            | <b>Gas Connection</b>  | 3/4"          |            |
| <b>Gas Consumption</b><br> | <b>Natural Gas</b>   | <b>LPG</b> | <b>Gas Pressure</b>  | <b>G30-31</b> | <b>G20</b> |
|   | 4.2 mc/h   | 3.2 kg/h   |  | 37 mbar       | 20 mbar    |
| <b>Weight</b><br>          | 1950 kg  |            | <b>Electrical Supply</b><br> | 230V/50Hz     |            |



We are a company, specializing in the manufacture of professional ovens for pizzerias.

AS TERM L.T.D  
144 Tsar Ivan Asen II  
4230 Asenovgrad  
Bulgaria

tel/fax +359 331 462 42  
[info@astermforni.com](mailto:info@astermforni.com)  
[www.astermforni.com](http://www.astermforni.com)

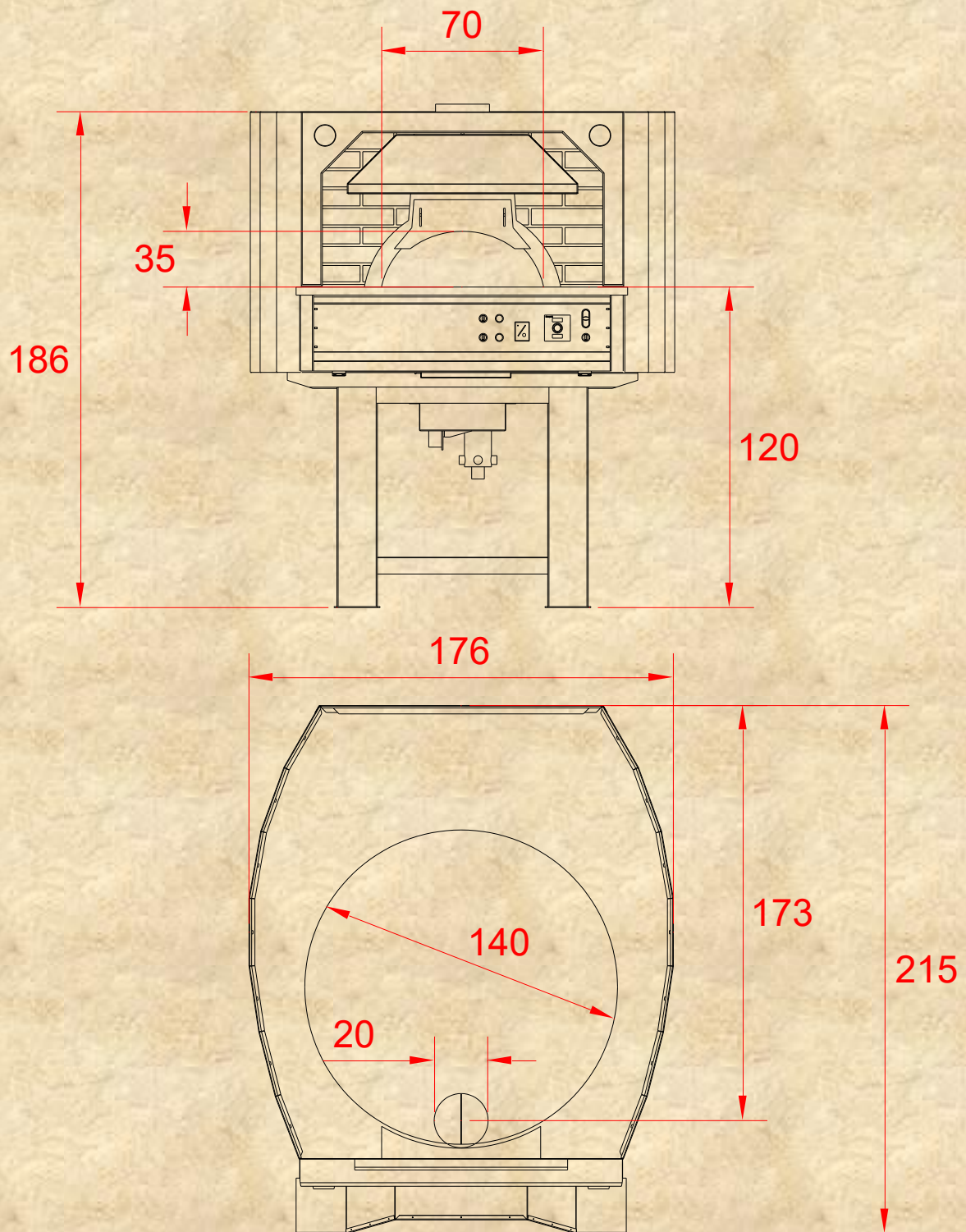

**\*Dimensions in cm**



We are a company, specializing in the manufacture of professional ovens for pizzerias.

AS TERM L.T.D  
 144 Tsar Ivan Asen II  
 4230 Asenovgrad  
 Bulgaria

tel/fax +359 331 462 42  
[info@astermforni.com](mailto:info@astermforni.com)  
[www.astermforni.com](http://www.astermforni.com)